

# **State Plaza**

Site Plan - Office Building

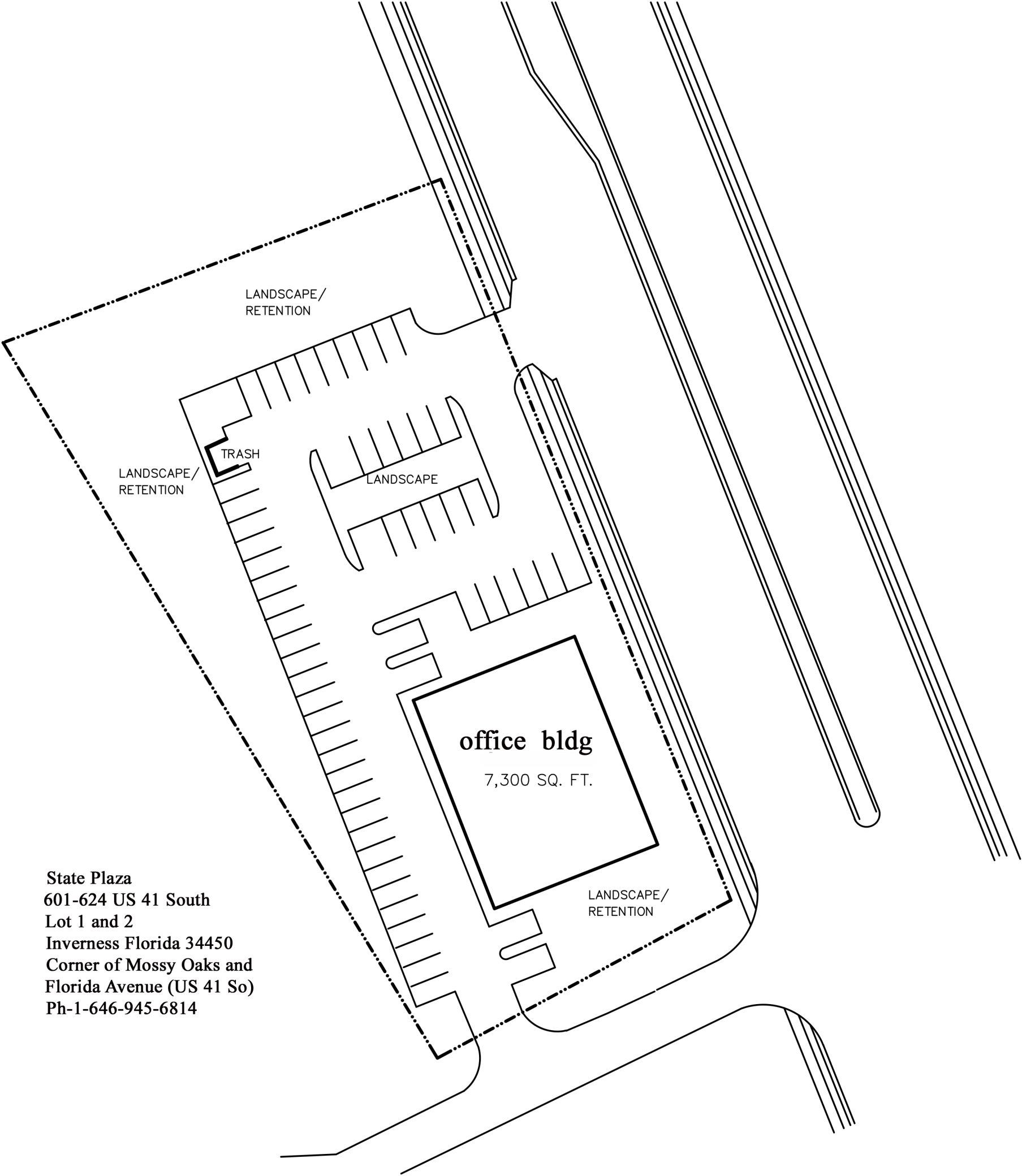

LANDSCAPE/  
RETENTION

TRASH

LANDSCAPE/  
RETENTION

LANDSCAPE

**office bldg**

7,300 SQ. FT.

LANDSCAPE/  
RETENTION

**State Plaza**  
**601-624 US 41 South**  
**Lot 1 and 2**  
**Inverness Florida 34450**  
**Corner of Mossy Oaks and**  
**Florida Avenue (US 41 So)**  
**Ph-1-646-945-6814**

# Site Plan - Retail with Office

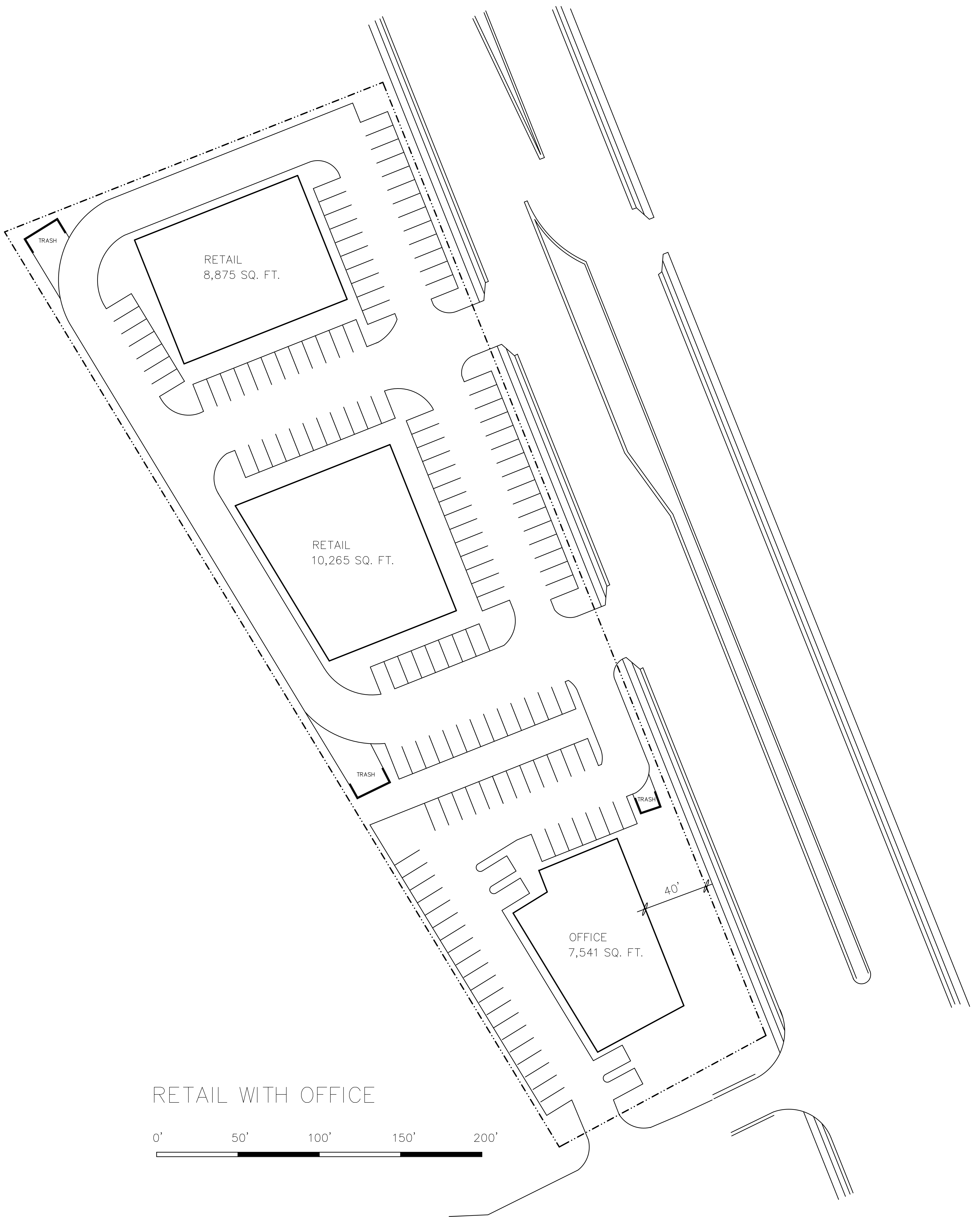

RETAIL  
8,875 SQ. FT.

RETAIL  
10,265 SQ. FT.

OFFICE  
7,541 SQ. FT.

40'

RETAIL WITH OFFICE

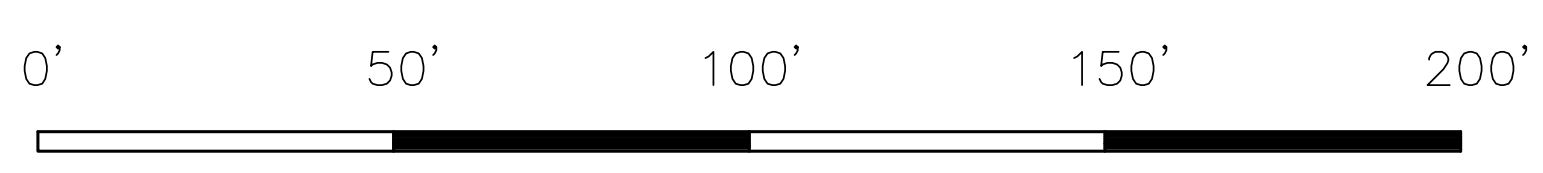

# Site Plan - Retail with Food Joint

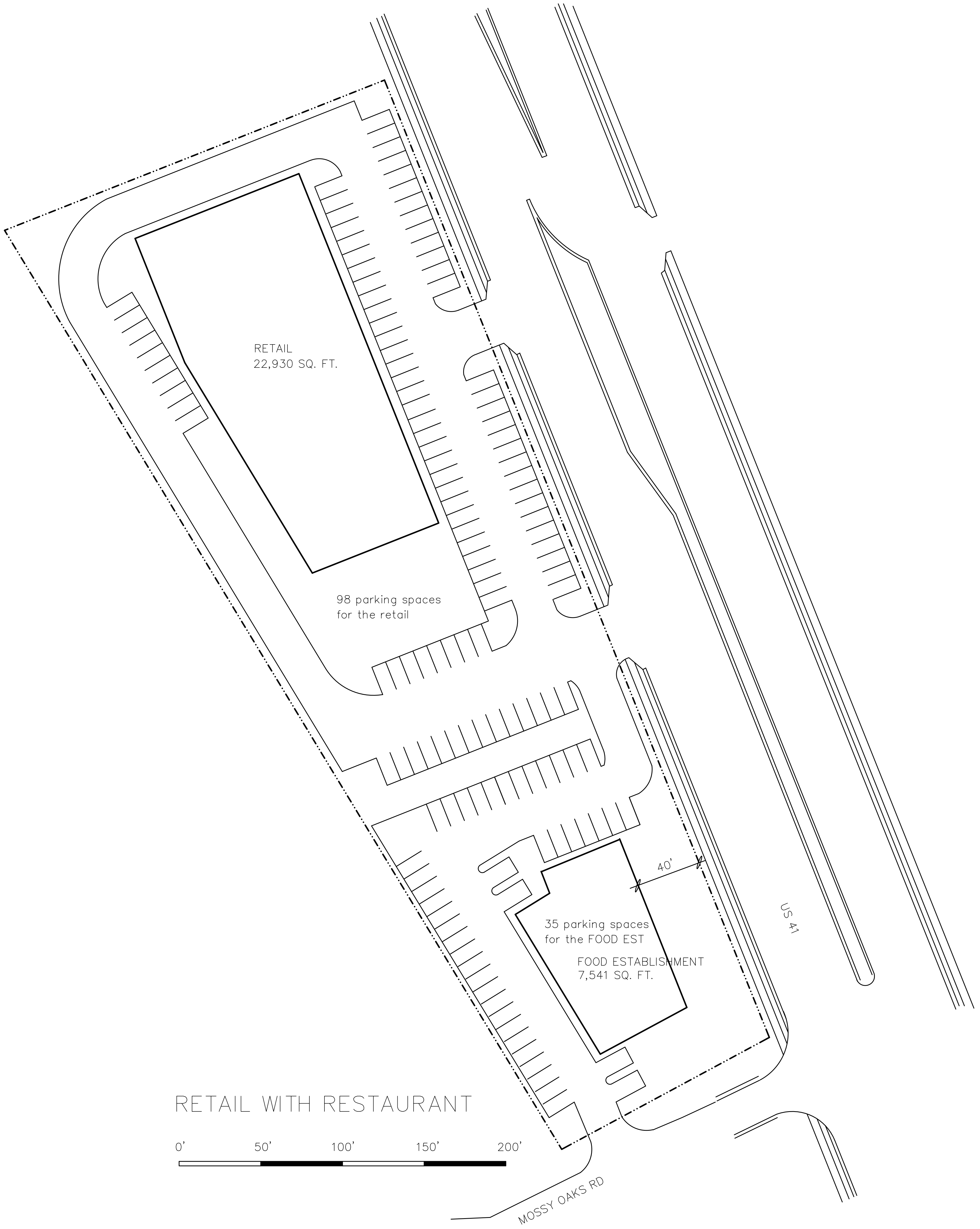

# Site Plan - Grocery Store with Restaurant

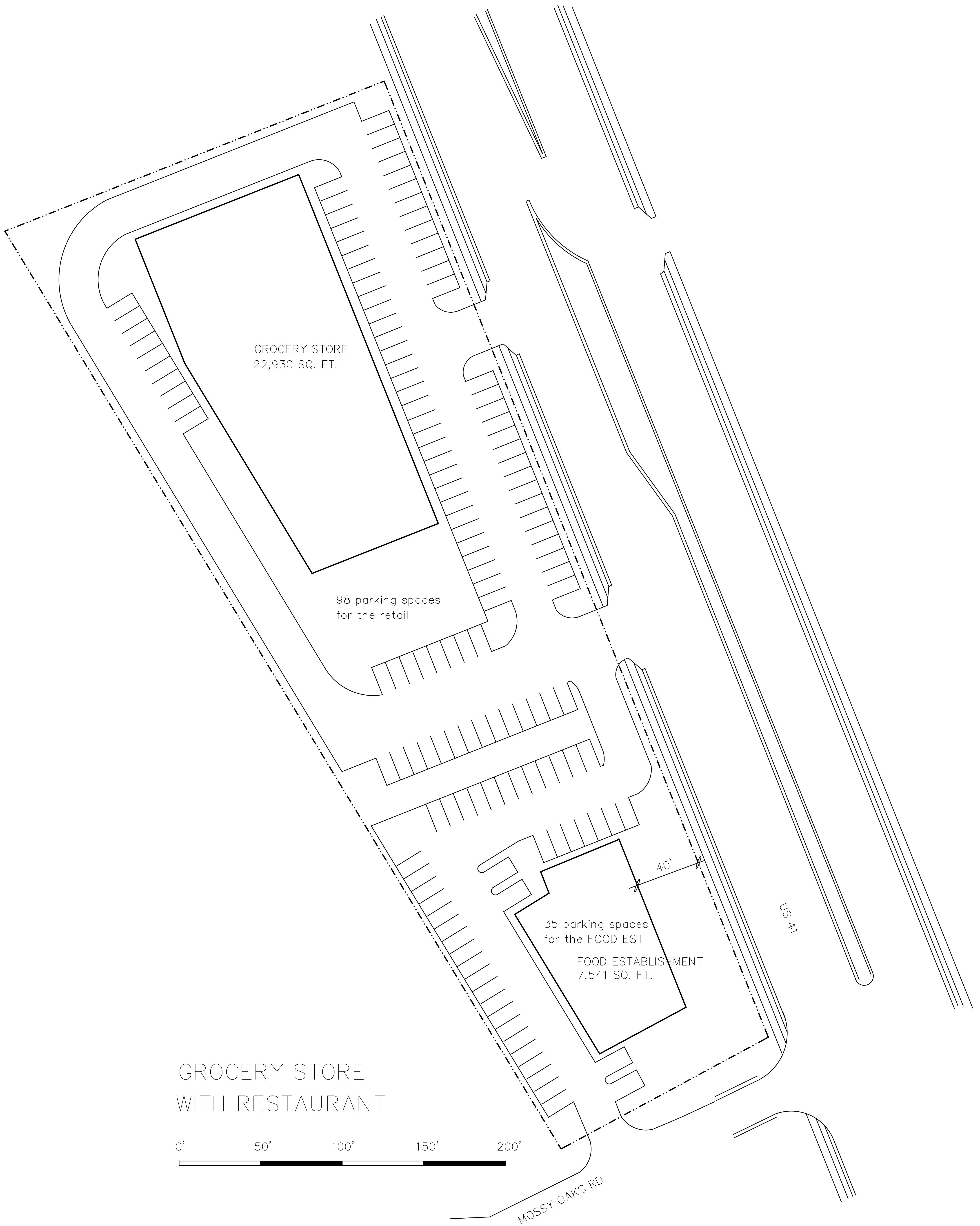

GROCERY STORE  
22,930 SQ. FT.

98 parking spaces  
for the retail

35 parking spaces  
for the FOOD EST

FOOD ESTABLISHMENT  
7,541 SQ. FT.

40'

GROCERY STORE  
WITH RESTAURANT

0' 50' 100' 150' 200'

MOSSY OAKS RD

US 41



# Site Plan - Mini Storage

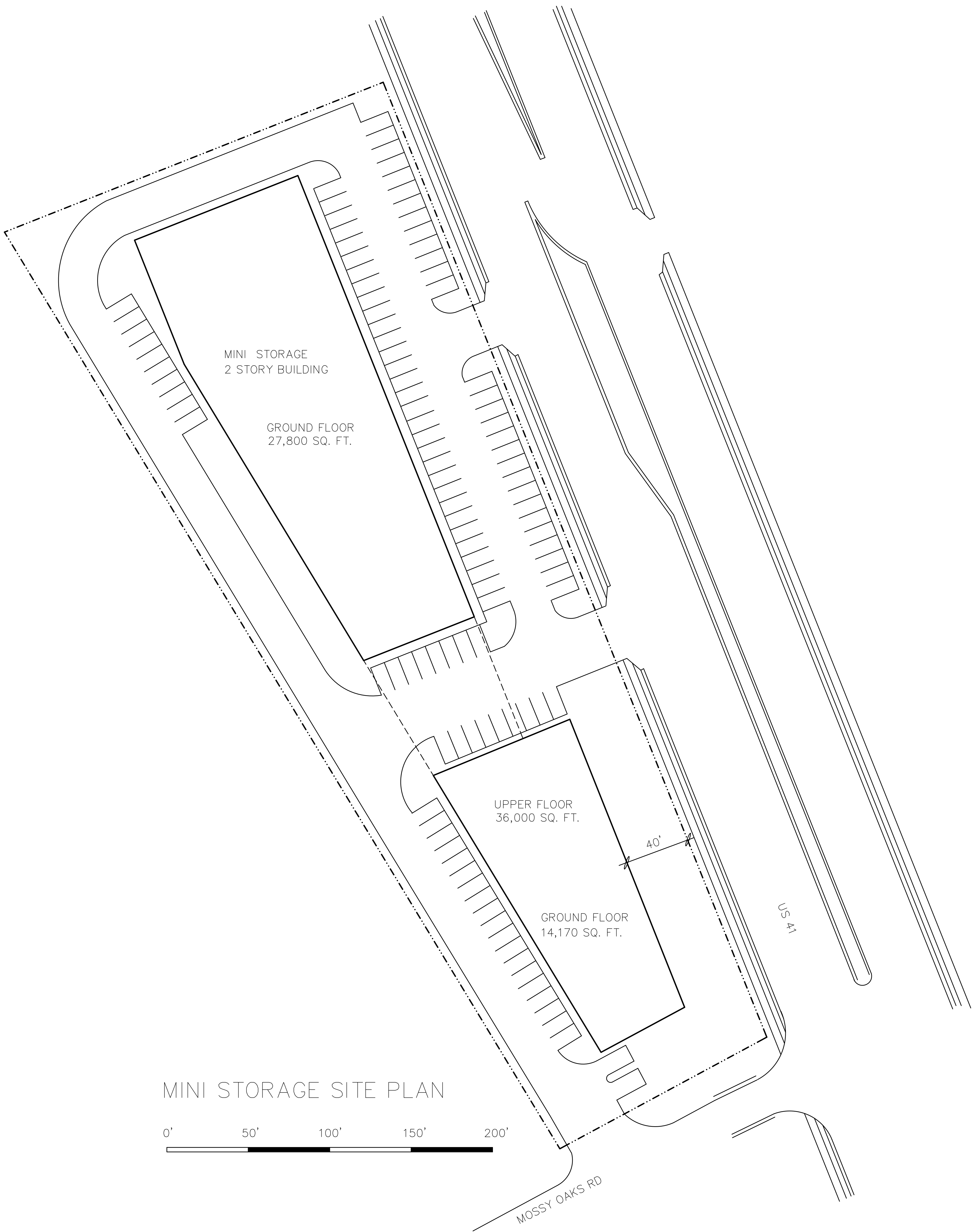

# Site Plan - Americinn

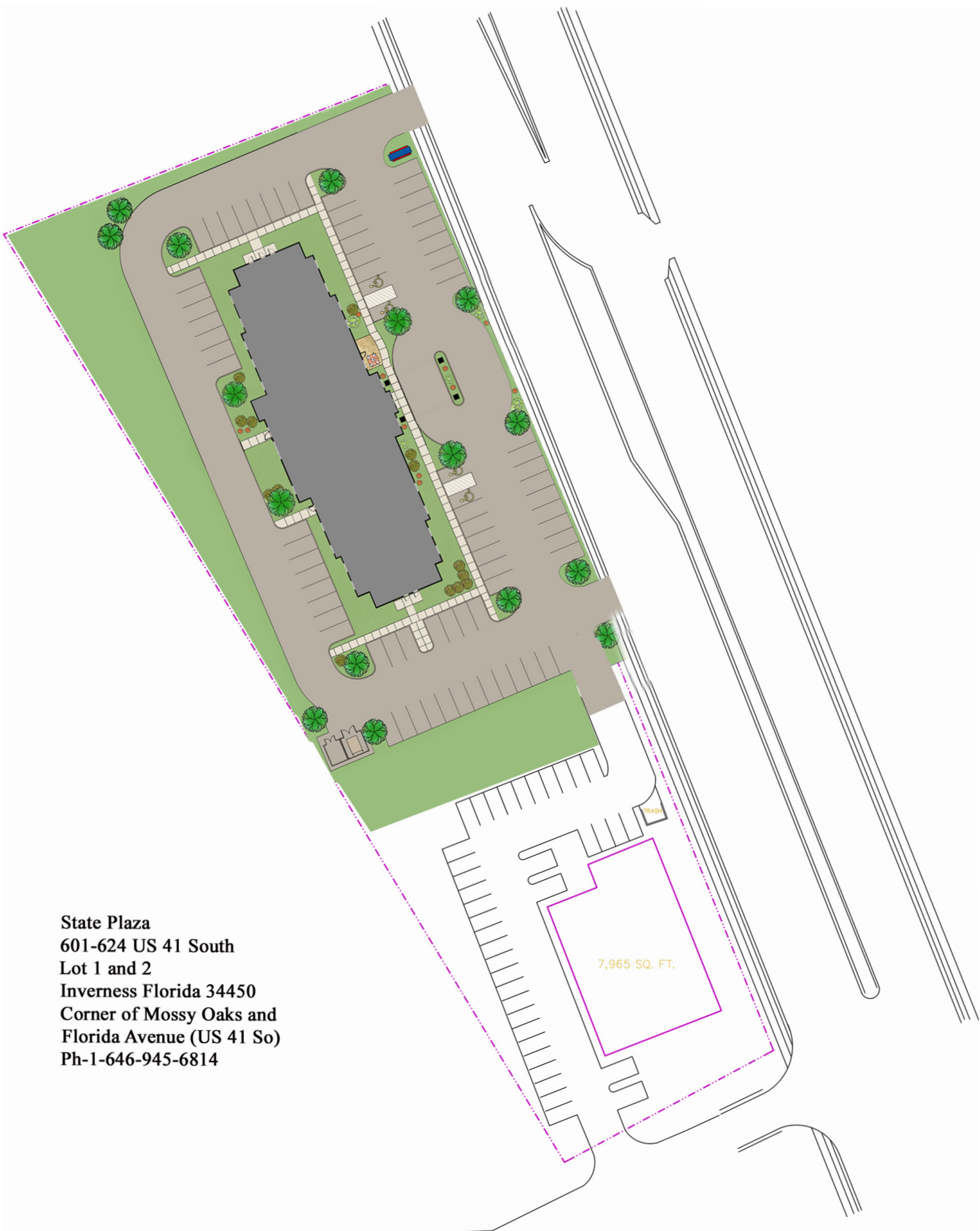

**State Plaza**  
**601-624 US 41 South**  
**Lot 1 and 2**  
**Inverness Florida 34450**  
**Corner of Mossy Oaks and**  
**Florida Avenue (US 41 So)**  
**Ph-1-646-945-6814**

# Site Plan - Microte

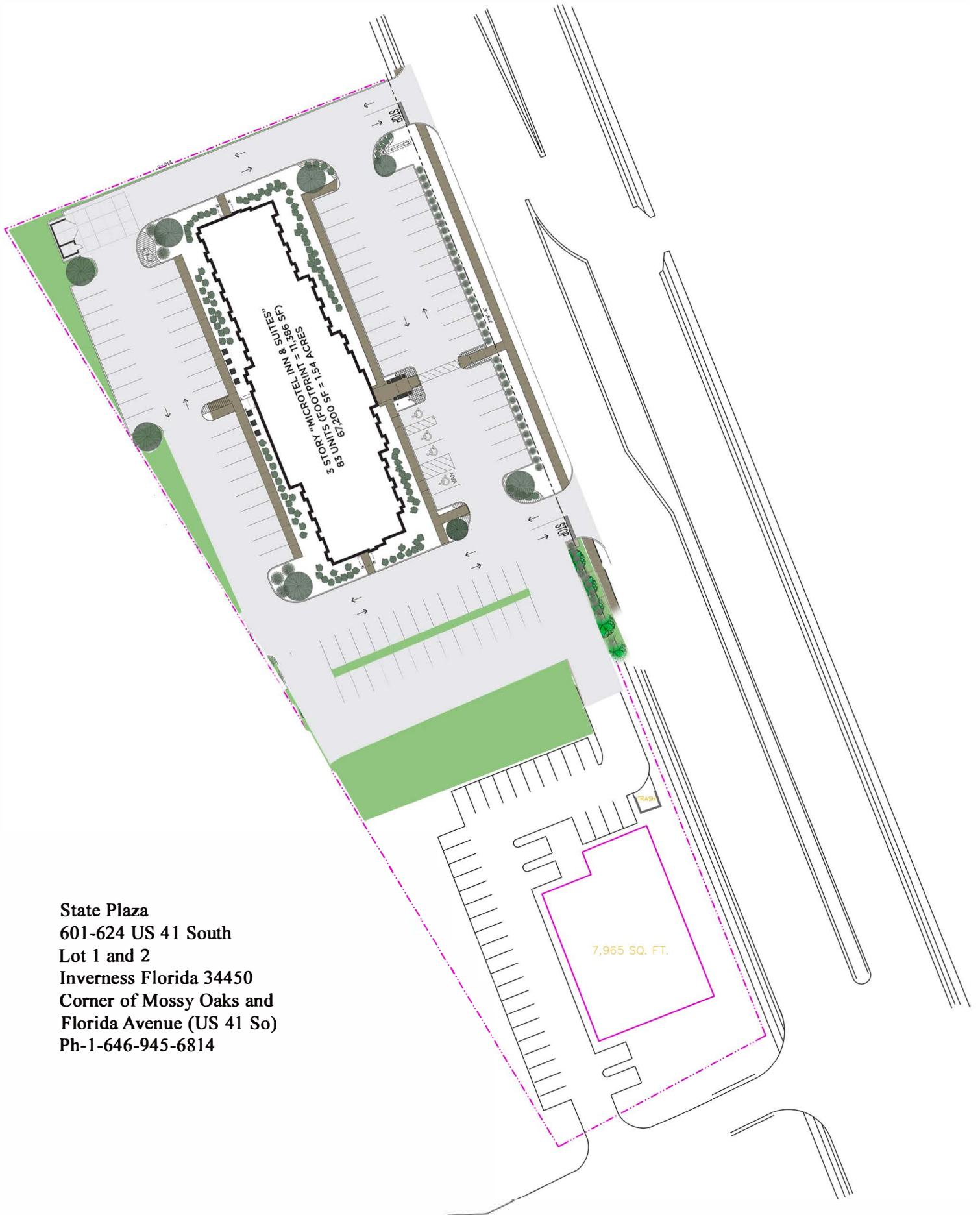

**State Plaza**  
**601-624 US 41 South**  
**Lot 1 and 2**  
**Inverness Florida 34450**  
**Corner of Mossy Oaks and**  
**Florida Avenue (US 41 So)**  
**Ph-1-646-945-6814**